

EMG30, mounting bracket and wheel specification

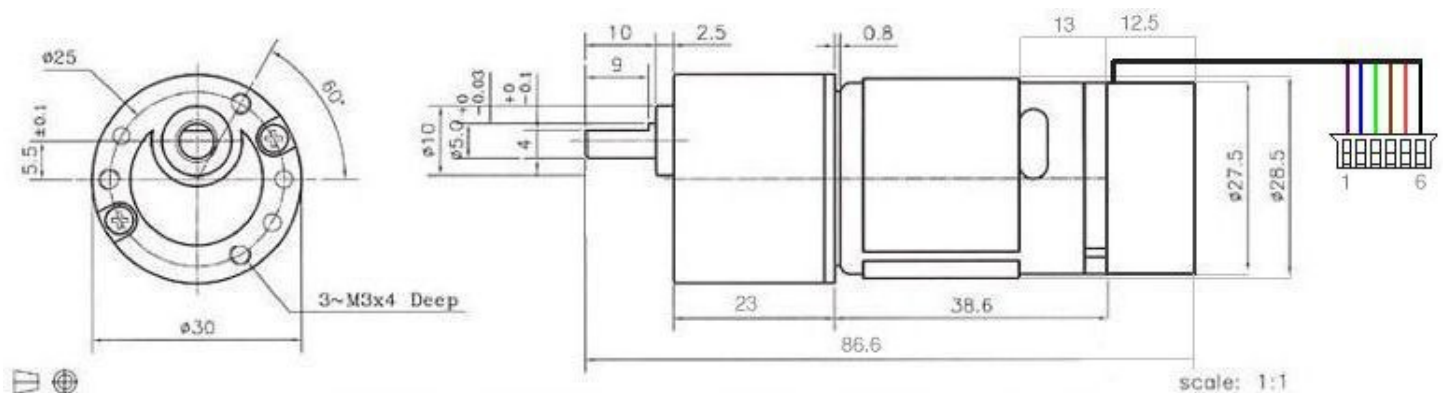

The EMG30 (encoder, motor, gearbox 30:1) is a 12v motor fully equipped with encoders and a 30:1 reduction gearbox. It is ideal for small or medium robotic applications, providing cost effective drive and feedback for the user. It also includes a standard noise suppression capacitor across the motor windings.

Measurements



Connector

The EMG30 is supplied with a 6 way JST connector (part no PHR-6) at the end of approx 90mm of cable as standard. The connections are:

Wire colour	Connection
Purple (1)	Hall Sensor B Vout
Blue (2)	Hall sensor A Vout
Green (3)	Hall sensor ground
Brown (4)	Hall sensor Vcc
Red (5)	+ Motor
Black (6)	- Motor

Wire colours are from the actual cable.

The hall sensors accept voltages between 3.5v and 20v.

The outputs are open collector and require pull-ups to whatever signal level is required.

On the MD25 they are powered from 12v and pulled up to 5v for the signals.

specification

Rated voltage	12v
Rated torque	1.5kg/cm
Rated speed	170rpm

Rated current	530mA
No load speed	216
No load current	150mA
Stall Current	2.5A
Rated output	4.22W
Encoder counts per output shaft turn	360

Measured Shaft Speed when used off-load with MD23 and 12v supply.

Minimum Speed	1.5rpm
Maximum Speed	200rpm

EMG30 Mounting Bracket

Providing easy mounting of the EMG30 to the robot, the bracket is made from a 2mm thick strong aluminum and finished in blue enamel.

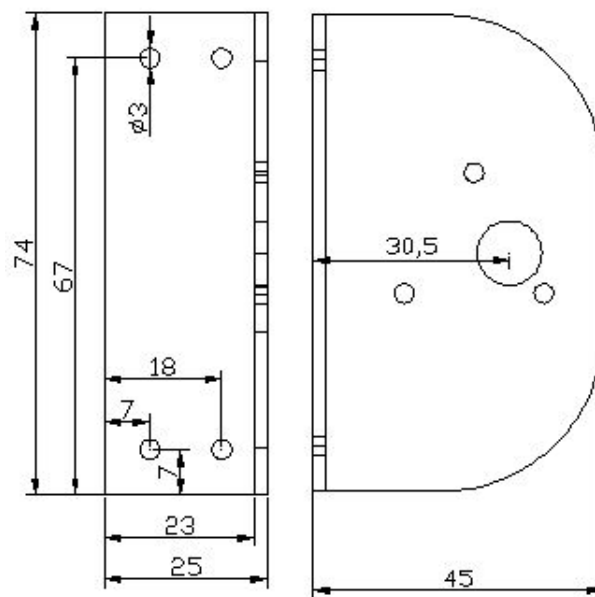

Wheel 100

A 100mm diameter wheel with 5mm diameter hub for easy attachment to the EMG30, the wheel has a 26mm wide rubber tread

