

# EMG30, mounting bracket and wheel specification

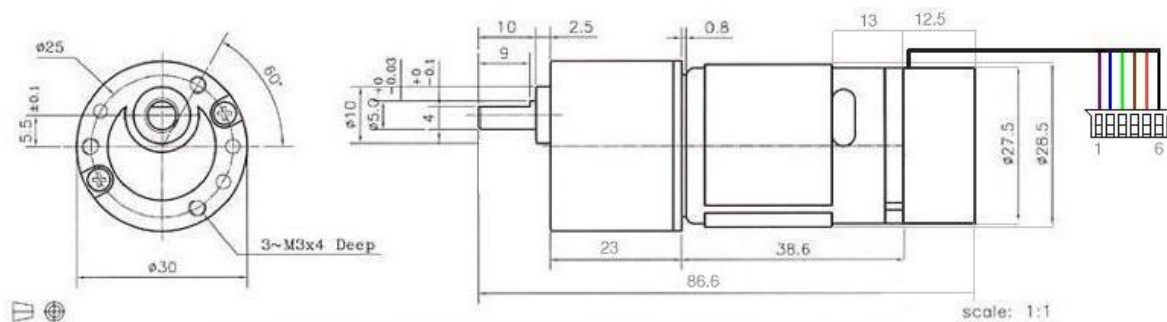

The EMG30 (encoder, motor, gearbox 30:1) is a 12v motor fully equipped with encoders and a 30:1 reduction gearbox. It is ideal for small or medium robotic applications, providing cost effective drive and feedback for the user. It also includes a standard noise suppression capacitor across the motor windings.

## Measurements



## Connector

The EMG30 is supplied with a 6 way JST connector (part no PHR-6) at the end of approx 90mm of cable as standard.

The connections are:

Wire colour	Connection
Purple (1)	Hall Sensor B Vout
Blue (2)	Hall sensor A Vout
Green (3)	Hall sensor ground
Brown (4)	Hall sensor Vcc
Red (5)	+ Motor
Black (6)	- Motor

Wire colours are from the actual cable. The hall sensors accept voltages between 3.5v and 20v and a maximum speed at 10000 rpm. The outputs are open collector and require pull-ups to whatever signal level is required. On the MD25 they are powered from 12v and pulled up to 5v for the signals.

## Specification

Rated voltage	12v
Rated torque	1.5kg/cm
Rated speed	170rpm
Rated current	530mA
No load speed	216 rpm

No load current	150mA
Stall Current	2.5A
Rated output	4.22W
Encoder counts per output shaft turn	360

### Constantes moteur

R = 7.1 Ohm  
L = 3.4 mH  
k = 0.017 Nm/A

### Measured Shaft Speed when used off-load with MD23 and 12v supply.

Minimum Speed 1.5rpm  
Maximum Speed 200rpm

### Réducteur

La réduction de vitesse est réalisée par 3 roues à doubles pignons entre le pignon moteur et la roue de sortie du réducteur.

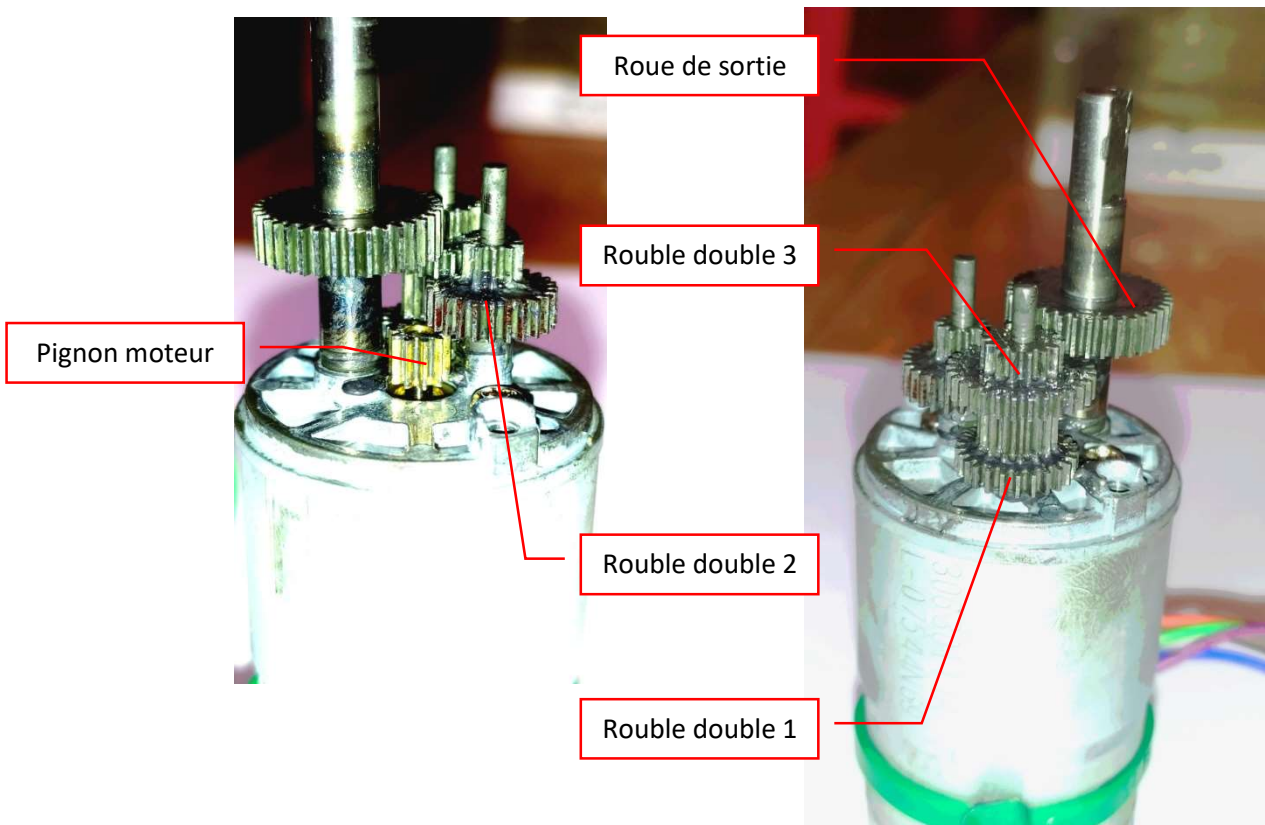

## Wheel 100

A 100mm diameter wheel with 5mm diameter hub for easy attachment to the EMG30, the wheel has a 26mm wide rubber tread .

